

Impulse and Momentum

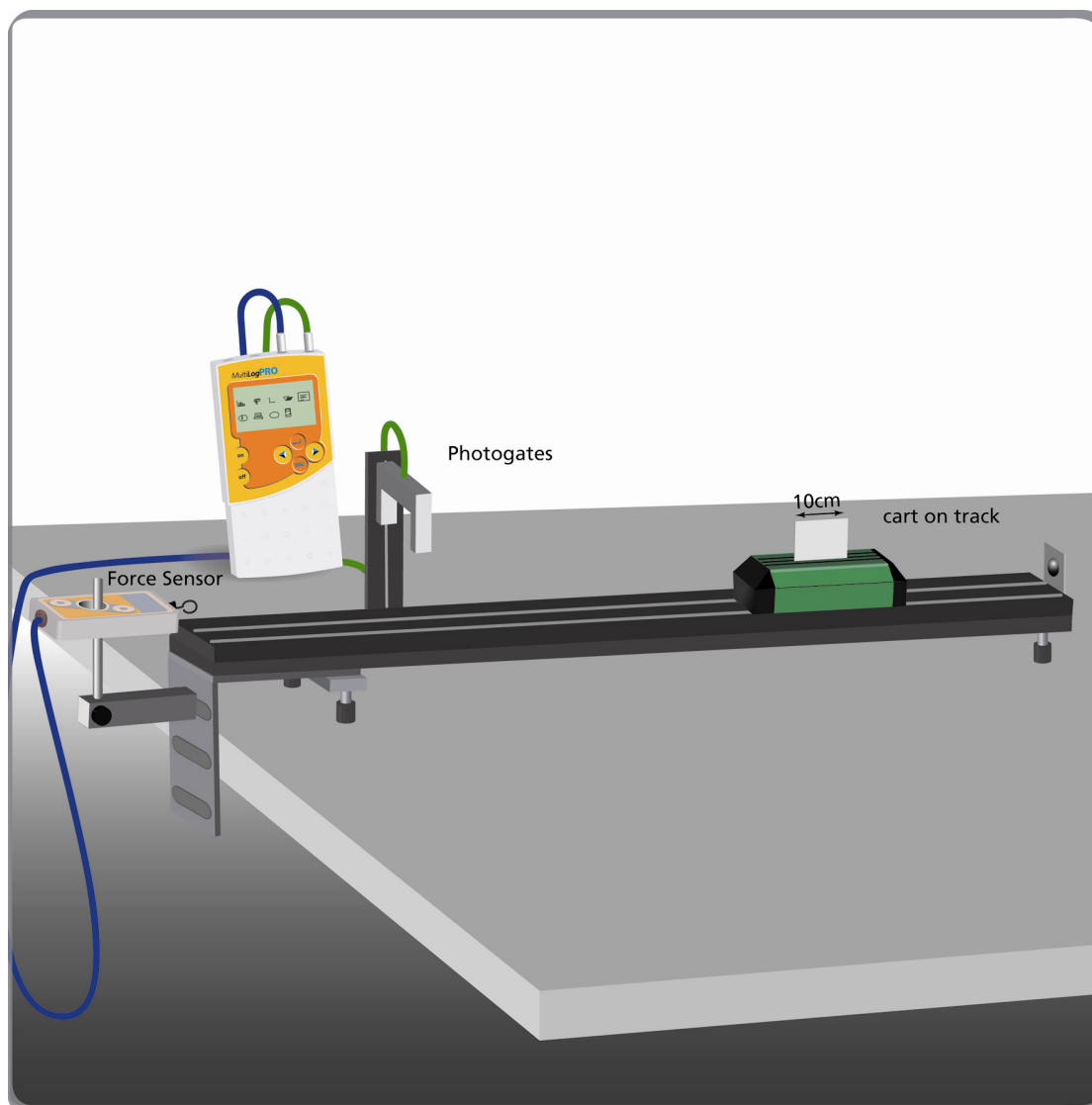

Figure 1

Introduction

Applying impulse to any body changes its momentum. The change in momentum equals the amount of impulse:

$$\Delta p = \int F dt$$
$$mv_2 - mv_1 = \int F dt$$



Where F is the force acting on the body, Δp is the change in momentum, m is the mass of the body and v_1 , and v_2 are the velocities of the body before and after impulse.

In this experiment a cart collides with a Force sensor and the change in momentum is compared to the impulse.

The impulse is found by calculating the time integral of the force measured by the sensor.

A photogate is used to measure the velocities of the cart before and after the collision.

Equipment

- Low friction cart on a suitable track.
- Piece of cardboard 10cm in length.
- Laboratory scales.
- MultiLogPRO or Nova or TriLink data logger
- Photogate
- Force sensor.

Equipment Setup Procedure

1. Connect the data logger to the serial port of the computer
2. Turn on the data logger
3. Connect the Photogate sensor to the I/O 1 port of the data logger
4. Connect the Force sensor to the I/O 2 port of the data logger
5. Assemble the equipment as shown by figure 1:
 - Attach a cardboard piece 10cm in length to the cart
 - Attach the force sensor to a table stand and position it at the end of the track, adjust the sensor's position so the cart can collide with it
 - Attach the photogate to a table stand and position it so that when the cart touches the force sensor the light from the source can reach the light sensor (see Figure 1). The piece of

cardboard should block the light when the cart passes through the photogate

6. Click **Setup Wizard**  on the main toolbar and program the data logger according to the setup specified below

Data Logger Setup

Sensors:

Input 1: Voltage 0 - 5V (the photogate is identified as a voltage sensor)

Input 2: Force

Rate:

3701 samples per second

Recording time:

2.7s (10,000 samples)

Experimental Procedure

1. Place the cart on the track away from the Force sensor, beyond the photo-gate. Make sure that the cart doesn't block the light
2. Click **Run**  on the upper toolbar to begin recording data
3. Push the cart towards the Force sensor. Make sure that the initial push is strong enough: after the collision. The cart must pass, on its way back, through the photo-gate so that its velocity after the collision can be calculated. Wait until logging stops and the data is automatically downloaded and displayed in the graph window

Note: If you are using MultiLog v.6 click **Download**  on the main toolbar to download the data

4. Measure the mass of the cart. Record this value in your notebook

Data Analysis

See figure 2 for sample data. The two rectangles represent the blocking of the photogate. The narrow peak at the center of the screen is the data from the Force sensor:

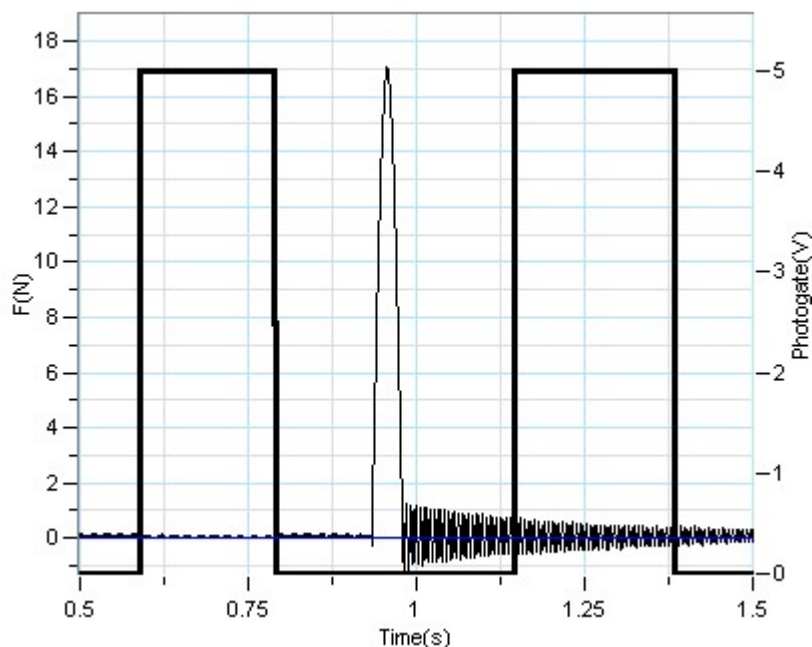

Figure 2

1. Calculate the change in momentum:
 - 1.a. Use the cursors to select, on the graph created by the photogate sensor, a range that includes both times when the light was blocked by the cardboard on the passing cart
 - 1.b. Use the Timing Wizard to calculate the velocities:
 - 1) click **Analysis** on the menu bar, then click **Timing Wizard**.
 - 2) Select **Velocity**, then click **Next**. Select **At one gate**, enter the cardboard width in the **Width** edit box, then click **Finish**. The corresponding velocities will appear in the **Timing Results** dialog. Record these velocities in your notebook

Add a minus sign to the second velocity because the cart is moving in the opposite direction.

- 1.c. Multiply the velocities by the mass m to calculate the momentum before and after the impulse:

$$p_1 = mv_1 \quad p_2 = mv_2$$

- 1.d. Calculate the difference in momentum:

$$\Delta p = p_2 - p_1$$

- 1.e. Record this value in your notebook

The Cursor: You can display up to two cursors on the graph simultaneously.

Use the first cursor to display individual data recording values, to select a curve or to reveal the hidden Y-axis.

Use two cursors to display the difference between two coordinate values or to select a range of data points.

To display the first cursor: Double click on an individual data point or click **Cursor**  on the graph toolbar. You can drag the cursor with the mouse onto any other point on the plot, or onto a different plot. For finer cursor movements use the forward and backward keys on the keyboard.

The coordinate values of the selected point will appear in the information bar at the bottom of the graph window.

To display the second cursor: Double click again anywhere on the graph area or click **2nd Cursor** .

The information bar will now display the difference between the two coordinate values.

To remove the cursors: Double click anywhere on the graph area, or click **1st Cursor** a second time.

To remove the 2nd cursor: Click **2nd Cursor** a second time.

2. Calculate the impulse:

- 2.a. Place the cursors on the force graph. Drag the cursors along the graph: the first cursor to the point when the force started acting, and the second cursor to the point on the graph when the force stopped acting on the cart

- 2.b. Click **Zoom in**  on the graph toolbar to focus on the part of the graph between the cursors (see Figure 3)

- 2.c. Click **Analysis** on the menu bar, then click **statistics**

- 2.d. Record the area in your notebook. This is the impulse. What are the impulse units?

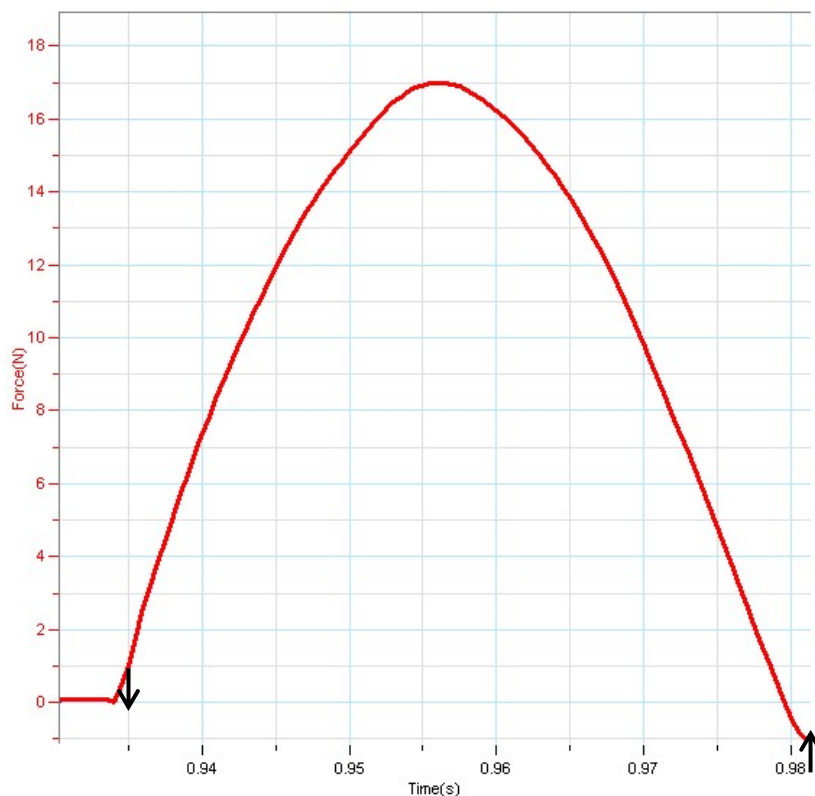

Figure 3

3. Compare the amount of impulse to the change in momentum. What are your conclusions?

Further Suggestions

1. The surface of the cart that collides with the Force sensor may be covered with different materials (cardboard, rubber, different metals or plastics). This will cause changes in the shape of the graph describing the impulse: the duration and the maximum force may change. Does the change of momentum still equal the impulse?
2. If a spring is attached to the cart, you can make the side of the cart with the spring collide with the Force sensor. This too will alter the shape of the graph. Does the change of momentum still equal the impulse?